



PIONEER
WATER TANKS



**Owner's Manual
and Warranty
Rural Water Tanks**





TANK OWNER INFORMATION

Name:

Address:

Town:

State:

Post Code:

Tank Dealer/Installer:

Contact details/stamp:

Date installed:

Anode replacement date:

Serial Number:

Tank model/size:

Thank you for purchasing a Pioneer Water Tank, which comes with a manufacturer's warranty. We hope you never need this warranty but if you do, our goal is provide prompt, efficient and effective service. To help us deliver the expected level of service we ask that you please register your warranty by completing the online registration at <https://pioneerwatertanks.com.au/>

Tank insurance is recommended. Your water tank is a valuable asset. Please consider contacting your insurance provider to include your tank in an insurance policy.



CONTENTS

Regular Maintenance of your Tank.....	4
Important Safety Notice	6
Base Aggregate	7
Removable Ladder Operation Procedure	8
Water (Overflow).....	9
Fitting Downpipes to Your Tank.....	10
Preventative Measures	11
Warranty Terms and Conditions	12
Warranty Procedure.....	15
Contact Details	Back



REGULAR MAINTENANCE OF YOUR TANK

Frequency of Inspections

- We recommend a quarterly visual external inspection (as described below) of your water tank either by the owner or their nominated contractor or site personnel. The optimum time for inspection is prior to first rain and every 3 months thereafter. At all times due diligence should be taken with regards to personal safety.

Tank perimeter must be clear of vegetation

- Treat the area around your tank with a suitable and safe vegetation deterrent (please refer to Preventative Measures on Page 11 for further information).
- Ensure the aggregate around the perimeter is dissipating the roof run-off water as it should. If the sand base appears to be eroding, back fill immediately and place more aggregate around the tank wall. Continue to check the aggregate is dissipating water run-off (please refer to Aggregate on page 7 for further information).

Cleaning of tank roof

Use a long handled or extendable broom to sweep leaves and debris from the tank roof, if possible from ground level. Walking on the tank roof is not recommended.

Roof mounted filter basket (if fitted)

Remove the downpipe and black filter basket cover then lift out the filter basket to clean out any debris. Ensure the basket and cover are replaced correctly to prevent sunlight entering the tank as sunlight will encourage the growth of algae. It is important to conduct this task before the first rain and every time after it rains.

Rain first flush diverter (if fitted)

Unscrew the inspection cap to clean out any collected debris and replace the cap.

Pest or vermin activity

Check for any signs of pest or vermin activity, burrowing or damage around the tank. Any concerns need to be attended to immediately. Damage to the tank or tank liner caused by pests, vermin or other animals is not covered by the warranty.

If necessary, treat the perimeter of the tank with a suitable and safe pest or vermin deterrent. Ensure you follow the advice of a qualified professional (please refer to Preventative Measures on Page 11 for further information).



Sacrificial magnesium anodes are fitted to your tank for additional corrosion protection and they must be replaced every 5 years to meet warranty conditions. They may need to be replaced earlier and more frequently if the tank is located in a more corrosive environment, for example coastal plains, industrial areas, or where soils are more highly acidic or alkaline. Please immediately contact your local Dealer if there are signs of corrosion on the tank. Your local dealer can also assist in replacing the anodes at the 5 year interval or earlier if required.

Cleaning tank walls (external)

To keep your tank looking good and to prevent the build-up of surface contaminants, which can lead to surface corrosion, we recommend periodically washing the outside of your tank with clean water and a soft bristled brush or broom.

Hose the tank panels down and use the soft brush to remove any dust, dirt or salt spray. If the sand pad or aggregate is disturbed, it must be rectified immediately.

Please refer to the BlueScope Steel Technical Bulletins for further information on the correct care of Zinalume® and Colorbond® steel surfaces.
<http://steelproducts.bluescopesteel.com.au/category/technical-bulletins>

Poly and PVC tank fittings

We recommend all external poly and PVC fittings and down pipes exposed to sunlight be painted with UV resistant paint to extend their lifespan.

Internal tank cleaning

Ensuring you have a well-designed and maintained water supply system is the key to avoiding the need to clean the inside of your water tank. If your water catchment surfaces (roof) and gutters, along with your tank pre-filtration systems such as leaf catcher, first flush diverter and leaf filter basket are kept clean and well maintained, then your tank should not require internal cleaning.

Our strong advice is to avoid the need to enter your tank to eliminate the associated risk to your personal safety and the potential for accidental damage to the internal tank liner, which may compromise the water holding ability of your tank.

Pioneer strongly recommends contacting your local Pioneer Dealer for advice on engaging a trained and experienced tank cleaner. Before you enter the tank for any reason, please contact Pioneer Water Tanks or your local Pioneer Dealer for further guidance.



IMPORTANT SAFETY NOTICE

THE DANGERS OF CONFINED SPACES

Access to the tank for visual inspection of the internals (as observed from the outside of the tank) is provided via the ladder and roof access hatch. Pioneer strongly recommends that the access hatch is properly secured and padlocked at all other times and that the ladder is removed when not in use to prevent Unauthorised access into the tank.

Children should be supervised at all times when in the vicinity of the tank and at no time should children be permitted to enter the tank. You are solely responsible for preventing access to the tank by Unauthorised persons or children.

The inside of a water tank is considered a confined space. The internal environment of a confined space may not support human life. Never use a petrol powered pump or cleaning device inside a water tank.

Any confined space poses a potentially life-threatening hazard, because the threat may not be apparent until it is too late. Water tanks and other enclosed structures can suffocate a person with vapours, toxic gases or low oxygen levels.

Inexperienced or untrained rescuers coming to the aid of someone who has collapsed inside a confined space are usually exposed to the risk too. There have been occurrences for other members of the same family to suffer a serious injury or death in a single confined space accident.

Advice on managing safe access to a confined space is available from Safe Work Australia or from the safety regulator in your state or territory. If in doubt, you should also contact Pioneer Water Tanks or your local Pioneer Dealer for further guidance.

WARNING

The safest approach is to avoid entering the confined space within the tank.

When fitting a valve or pipework to the external outlet fittings on your tank, hold the tank outlet fitting securely to avoid it rotating as you tighten the connection. Failure to do so will allow the tank outlet to rotate which may result in leakage occurring.



Base Aggregate

It is the owner's responsibility to ensure sufficient coarse aggregate is immediately placed around the outside perimeter of the tank to prevent erosion of the sand pad and around the tank base. Causes of erosion can include roof water run-off, extreme weather conditions, stock animals, burrowing native animals, pests and vermin.

The initial placement and maintenance of sufficient coarse aggregate around the tank base to prevent erosion is a condition of warranty. Additional aggregate may need to be added around the tank perimeter during the service life of the tank to replace any aggregate that subsides or is otherwise removed during service.

The aggregate can consist of any combination of the following inert materials:

- Blue metal (25-30mm)
- Rocks or gravel (25-30mm)
- Broken & crushed bricks or masonry (25-30mm)
- Other hard and inert natural material (25-30mm)

Pre-cast concrete slabs, concrete blocks or full bricks are not suitable for use.

NOTE: Do not use aggregate, which may have been used or recycled from any commercial site, mining operation or industrial processing plant. It may contain chemical residues and corrosive substances that can damage your tank and void the warranty.

PLEASE REFER TO THE ILLUSTRATION ON PAGE 8



Removable Ladder Operation Procedure

Your water tank is supplied with a removable (hook-on/hook-off) ladder, designed to give occasional access to the top of the tank to inspect the water level through the lockable roof hatch or access to the inlet filter basket for cleaning.

To prevent Unauthorised access, the ladder should be stored in a secure place away from the tank when not in use.

Pioneer also recommends that the access hatch be padlocked and the key stored in a secure location away from children for added precaution.

Walking on the roof is NOT recommended.

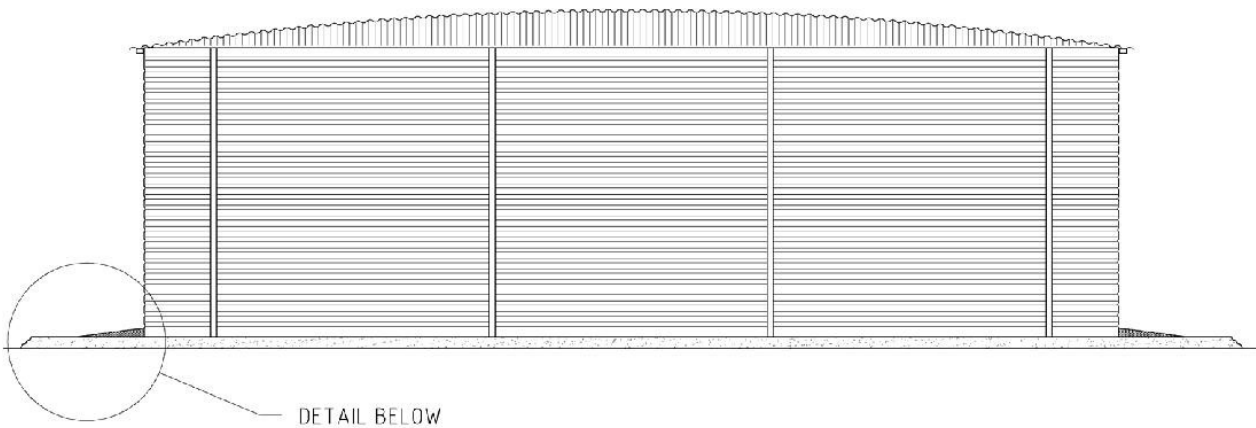

DETAIL BELOW

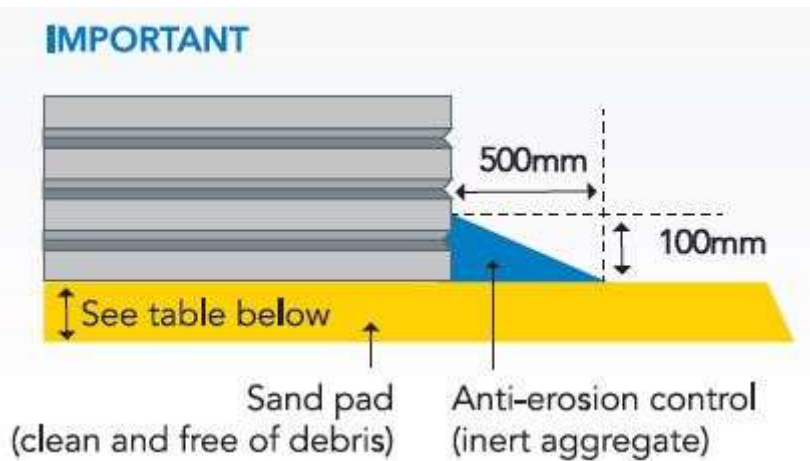



Water

Immediately after your tank is built, a minimum level of 300mm of water must be placed in the tank to fix the tank liner firmly in place. This must happen on the day of installation to prevent the tank liner from moving around or billowing up due to wind or other conditions. The supply of water on the day of installation is the sole responsibility of the purchaser. If water is not immediately added to the tank then this may void your warranty.

Tank owners need to advise all water tanker operators to take **EXTREME CAUTION** when pumping water into the tank to prevent any damage to the liner. Unrestrained hoses with metal end fittings will create irreparable damage to a tank liner.

Internal Bellmouth/Overflow

The overflow on your Pioneer Water Tank is fitted with an internal elbow and bellmouth which allows the maximum height of the water to reach 2030mm.

See illustration:

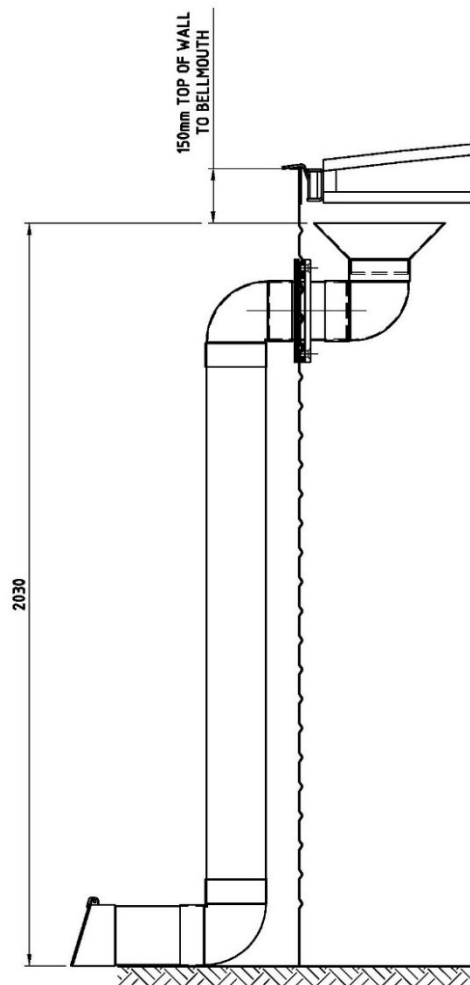

ELEVATION OF OVERFLOW



Fitting Downpipes to Your Tank

Where tanks are top-filled through downpipes via the filter basket, holes must be cut into the lid covering the filter basket to allow the insertion of the down pipes. The center point of any holes cut for 90mm or 100mm diameter downpipes must be at least 90mm from the outer edge of the lid.

The center hole should be reserved for inspection and cleaning of the leaf basket. Please ensure the lid and the center cap are always replaced after removal to avoid UV damage to the basket. The ingress of UV light into the tank will also promote the growth of algae inside the tank, so always prevent sunlight from entering the tank.

The installation of downpipes and all associated pipework must be completed in accordance with the relevant regulations and standards.

See illustration:

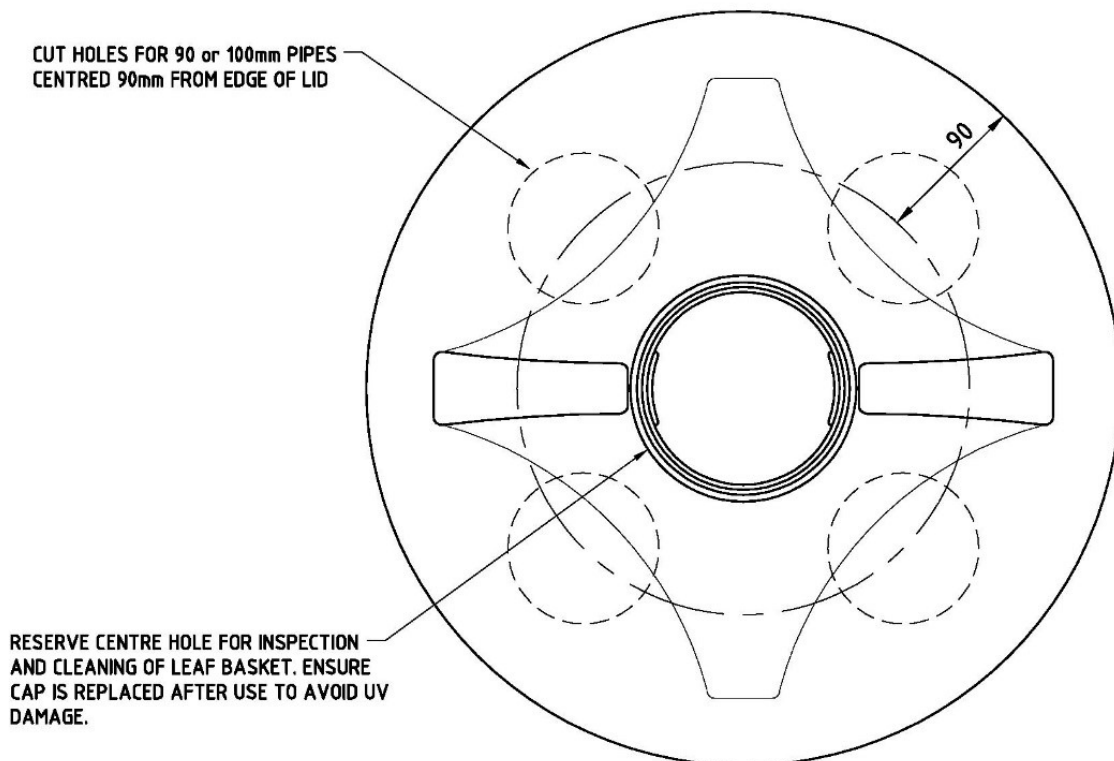

PLAN VIEW OF LEAF FILTER BASKET



Preventative Measures

As clearly stated in our warranty terms and conditions, root intrusion, ant invasions and pest or vermin attacks are not covered by the warranty in any circumstances.

The below information is only a recommendation for preventative measures. Please take into account that every situation is different.

Root Intrusion

- Remove all trees and plants within 5 to 10 metres of the tank. Totally remove any plants on the property with invasive root systems such as running bamboo or genus ficus plants.
- Where trees with invasive root systems cannot be removed or the owner does not wish to remove then it is recommended that trenching around the tank to disturb the root systems be undertaken on an annual.
- If in doubt, seek professional advice from a local horticulturalist on vegetation in your area.

Pests

- Seek professional advice from a local licensed pest exterminator.
- Ensure all openings into the tank are covered or closed to prevent pests and vermin from entering.
- Ensure aggregate is placed at the base of the tank as per our warranty document to prevent rodents and other native animals from burrowing underneath the tank.



Warranty Terms and Conditions

Steel water tank and liner

Pioneer provides an additional manufacturer's warranty as set out below to the purchaser for the steel structure of the tank body and the water retaining liner membrane against defects in material and/or workmanship resulting in leakage, for a period of 20 (twenty) years from the date of installation. The liability of Pioneer under this warranty is limited to a pro-rata share of the original purchase price as set out below. Where the water tank is installed outside the boundaries of a metropolitan area as defined by Pioneer or further than 100km from a Dealer's office, the cost of transport, accommodation and travelling between the nearest Dealer's office and the installed site shall be the owner's responsibility. Pioneer also warrants the steel water tank and liner including any accessories against damage or defects sustained as a result of installation by Pioneer or its Dealers for a period of 12 (twelve) months from the date of installation.

Rights of consumers under Australian Consumer Law

1. Clause 2 applies to you if:
 - a. the amount paid or payable for the steel water tank and liner did not exceed \$40,000 (except where the steel water tank and liner is not of a kind ordinarily acquired for personal, domestic or household use or consumption, and Pioneer Water Tanks has limited its liability in a manner permitted by Australian consumer law, in which case your rights are limited to that extent); or
 - b. the steel water tank and liner is of a kind ordinarily acquired for personal, domestic or household use or consumption, unless you acquired the steel water tank and liner for the purpose of re-supply or the purpose of using it up or transforming it in trade or commerce.
2. Pioneer Water Tanks products come with guarantees that cannot be excluded under Australian consumer law. You are entitled to a replacement or refund for a major failure and compensation for any other reasonably foreseeable loss or damage. You are also entitled to have the goods repaired or replaced if the goods fail to be of acceptable quality and the failure does not amount to a major failure.
3. The benefits given to you by this warranty are in addition to other rights and remedies you may have under a law in relation to the steel water tank and liner.



Limitations and qualifications

4. Subject to Pioneer's obligations under applicable laws which cannot be excluded, modified, or restricted under law, including as described in clauses 2 and 3:
- a. **This warranty is conditional upon:**
 - i. Pioneer being notified of any defect within 1(one) month of the defect becoming apparent.
 - ii. Quotation of the tank serial number displayed on your tank.
 - b. **Warranty shall apply, provided the following conditions are met:**
 - i. Tanks installed on either a clean inert sand pad, reinforced concrete slab or ring beam and with inert aggregate placed around the tank and in accordance with Pioneer's recommendations.
 - ii. Tanks fitted with a Pioneer steel dome roof at time of installation.
 - iii. Tanks installed by Pioneer personnel or Dealer.
 - iv. Tanks where the anodes are replaced every 5 years from installation date. Proof of purchase will be requested to be produced if required.
 - v. Tanks where regular maintenance has been carried out in accordance with the Pioneer Owner's Manual.
 - vi. Tanks where all payments have been received in full.
 - c. **Warranty shall not apply in the event of any of the following situations:**
 - i. Damage from tank pad and foundation settlement or movement.
 - ii. Storage of products other than potable water.
 - iii. Misuse or abuse of the tank or liner.
 - iv. Accidental or malicious damage to the tank or liner.
 - v. Natural disaster (including without limitation fire, flood & cyclone) or force majeure.
 - vi. Damage from vegetation or root intrusion.
 - vii. Damage caused by Pests or livestock.



- viii. Corrosion or fading of the tank exterior or any other components, accessories, fittings or fixings caused by adverse environmental conditions or due to the presence of Unauthorised fittings or fixtures (e.g. electrolysis due to dissimilar metals).
- ix. Damage as a result of unreported leakage.
- x. Unauthorised modifications, alterations and/or additions to the tank or its fittings or any damage caused by such modifications, alterations and/or additions.
- xi. Relocation of the tank other than by Pioneer or its Dealers.
- xii. Where the tank liner has been exposed to sunlight.
- xiii. Other Non-workmanship issues.
- xiv. Damaged caused by chemical attack, and in particular chlorine attack resulting from utilisation of an unapproved chlorine dosage method, or as determined by Pioneer.

Subject to 4(a), (b) and (c), if a claim is made under this warranty Pioneer will, at its sole discretion, either repair or replace the tank body and/or liner should leakage have developed due to a fault in material and/or workmanship within the warranty period provided that the total liability of Pioneer under this warranty is limited to the part of the original purchase price that bears the same ratio to the original price as the remaining term of the warranty period (as at date on which the warranty claim is notified to Pioneer) bears to the full warranty period.

To the extent that the value of any repair or replacement exceeds the liability of Pioneer under this warranty, such repairs or replacement will be supplied at a discount equal to Pioneer's liability.

THIS WARRANTY IS NON-TRANSFERABLE AND ONLY APPLIES TO THE ORIGINAL END USER



In the event of a tank(s) being repaired and/or fitted with a new liner, by Pioneer or its Dealers, this warranty shall not be extended and shall apply only for the remainder of the original warranty period.

The terms and conditions set out in this warranty constitute the entire agreement between Pioneer and the owner with respect to their subject matter. The benefits conferred by this warranty are in addition to all rights and remedies granted by law provided that, to the extent permitted by law, Pioneer excludes any other warranties and conditions (express or implied)

In relation to the tank and liner, including (without limitation) any warranty relating to its description, quality or fitness for purpose. Where Pioneer's liability may be limited by law, Pioneer's liability in relation to any defect in, or supply of, the tank and/or liner is limited, at its sole option, to the repair of the goods, the replacement of the goods or the cost of the replacement or repair of the goods.

To the maximum extent permitted by law, Pioneer is not responsible for any direct, indirect, special, incidental or consequential losses or damages (including loss of water or consequential damage caused by leakage) resulting from any breach of warranty or condition or any defect in the tank and/or liner.

You will bear the cost of claiming the Warranty.

Warranty Procedure

To initiate a claim under this warranty you will be required to complete and submit a warranty claim form available on our website at www.pioneerwatertanks.com.au or by verbal request by contacting us on 1800 999 599 or by email at:

warranty@pioneerwatertanks.com.au.

Definitions

Dealer – means an authorised Dealer/Distributor of Pioneer Water Tanks

Non-Workmanship – means mechanical stress, environmental stress or external environment or otherwise determined by Pioneer

Pests – means vermin, ants, white-ants, termites or any other boring type of insects

Pioneer – means Pioneer Water Tanks Pty Ltd (ABN 65 604 579 651)

Pioneer's Specifications – means the Site Preparation document (PT08-01 D01)

Potable – means water as defined by the Australian Drinking Water Guidelines

Unauthorised – means any work undertaken by others not authorised by Pioneer

Workmanship – means the handling, assembly and manufacturing processes performed by on or behalf of Pioneer in order to manufacture the tank liner



PIONEER
WATER TANKS

Should you have any questions or concerns with your new water tank please follow the prescribed procedure and contact our Warranty and Service Department.

Australia Contact Details:

Toll Free: 1800 999 599

Phone: (08) 9274 4577

Fax: (08) 9274 4588

Email: warranty@pioneerwatertanks.com.au

Address: 23 Clayton Street, Bellevue, Western Australia 6056

Mailing: PO Box 1874, Midland, Western Australia 6936

www.pioneerwatertanks.com.au